



HP LaserJet Printer Family - 13.x Paper Jams, Troubleshooting, and Definitions

In this document:

■	Introduction
■	Interpreting the event log
■	Clearing jams from the HP Print to Mail accessory
■	Jam recovery for the HP Print to Mail accessory

Introduction

This document contains information about 13.xx paper jam error messages, as well as other control panel messages. This information relates to the HP LaserJet 4000, 4050 and 4100 printers, and the HP Print to Mail accessory. Below are the topics covered in this document:

- explains how to display and interpret the event log
- lists error messages and recommended solutions
- explains how to clear paper jams

Interpreting the event log

When the message PAPER JAM IN OUTPUT DEVICE appears on the printer control panel display, check the printer event log for information about the location of the jam.

NOTE: There is continuous communication (jam recovery support) between the accessory and the HP LaserJet 4050 printer. However, there is limited jam recovery support when using the HP LaserJet 4000 printer with the accessory.

To show the event log

1. Press MENU until INFORMATION MENU appears on the display.
2. Press ITEM until SHOW EVENT LOG appears on the display.
3. Press SELECT and then press GO.

The following table lists the 13.x error messages and provides possible solutions to clear paper jams.

HP LaserJet 4000, 4050 and 4100 printers			
Control Panel Message	Event Log Message	Explanation	Recommended Action
13.xx Paper Jam		Paper is jammed at the specified location (and possibly at other locations).	<p>For all paper jam messages, do the following:</p> <p>Remove jammed paper from the specified location. Check viewable paper path for other pieces of paper in the path.</p> <p>Open and close the top cover to clear the message.</p>
<p>13.1 PAPER JAM OR</p> <p>13.2 PAPER JAM</p>	13.01 or 13.02	<p>Paper delay jam at paper feed area (13.1) or</p> <p>Paper stopped jam at paper feed area (13.2)</p>	<p>For 13.1 and 13.2: Ensure that paper trays are loaded properly, so paper can feed from the tray.</p> <p>Check the input area for obstructions, such as paper in the path or visible damage to the paper path near Tray 1.</p> <p>Remove the toner cartridge and lift the green handle attached to the metal plate underneath. Check for paper in the paper path. Ensure that paper is feeding correctly from the appropriate tray. Inspect the pickup assembly by removing the paper tray to look inside the printer. Locate a rubber roller with a purple, plastic hub (paper feed roller). Directly behind the paper feed roller is the paper pickup assembly. The paper pickup assembly consists of a shaft with 4 half-moon shaped rubber and white plastic rollers attached to it. Rotate the shaft to locate the half-moon rollers and ensure that it turns easily. Immediately to the right of the shaft is a black plastic coupler shaped like a dog bone. If either the pickup assembly or the coupler is missing or damaged, the printer will need to be serviced.</p>

13.5 PAPER JAM OR 13.6 PAPER JAM	13.05 or 13.06	Paper delay jam at Fuser (13.05) or Paper stopped jam at Fuser (13.06)	For 13.5 and 13.6: Look underneath the toner cartridge and lift up the trap door with the green handle and check for obstructions in the paper path. Check the rear area of the printer for obstructions.
13.10 PAPER JAM	13.10 or 13.22	Paper delay at paper reversing area or Paper jam at duplexer	Check the Duplexer and the rear area of the printer for obstructions or damage.
13.20 PAPER JAM	13.20 or 13.32	Paper stopped jam in the paper path	For 13.20 and 13.21: Check the entire paper path for obstructions, such as paper in the path, under the toner cartridge (look under the trap door with the green handle), in the rear of the printer, or in the Tray 1 area.
13.21 PAPER JAM	13.21 or 13.33	Door open jam	Check that all doors are closed.
HP Print to Mail accessory			
Control Panel Message	Explanation	Recommended Action	
12.01	Paper in input during startup. The accessory is not running. During an internal test at startup, a page was found at the accessory input. The print job has not run and there should not be a jam in the printer.	<ol style="list-style-type: none"> 1. Remove the page. 2. Clear the paper path in the accessory. 3. Make sure that the accessory power switch is set to the on position. 4. Reset the accessory. 	

66.xx.yy	The accessory is not running.	<ol style="list-style-type: none"> 1. Clear the jam in the accessory, or reconnect the accessory power cable and accessory interface cable (C-Link), checking for damaged or bent pins. 2. Reset the accessory. 3. Turn the printer off and then back on (your print job will be lost).
--	The paper at input is too long. The print job was in process. A jam is likely to be located at the accessory input.	<ol style="list-style-type: none"> 1. Clear the jam in the accessory. for more information. If there is also a jam in the printer, clear the printer. 2. Reset the accessory.
--	The paper did not exit. The print job was in process. A jam is likely to be located inside the accessory.	<ol style="list-style-type: none"> 1. Clear the jam in the accessory. If there is also a jam in the printer, clear the printer. 2. Reset the accessory.

Clearing jams from the Print to Mail accessory

1. Press the power switch to standby.

Step 1: Setting the accessory to standby

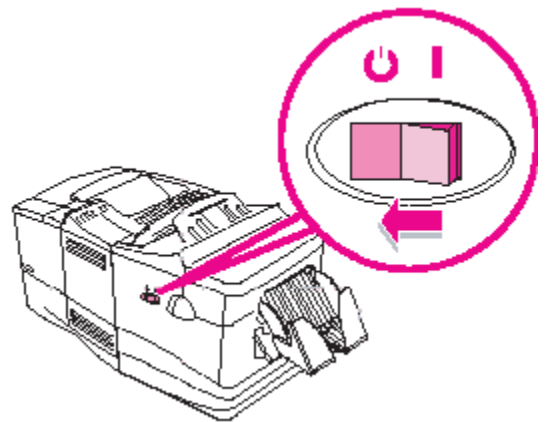

NOTE: Do not turn off power to the printer. All print job information will be lost.

2. Press the thumb tabs to remove the upper fold-chute. Do not attempt to open the top cover until the upper fold-chute is removed.

Step 2: Remove the upper fold-chute

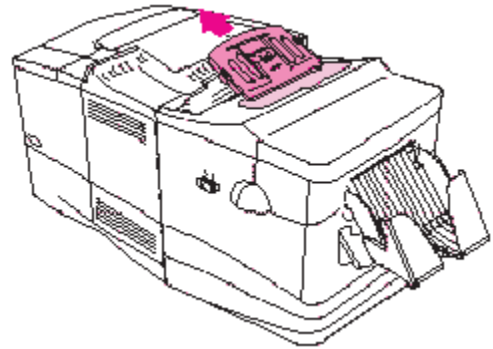

3. Open the top cover of the accessory.
4. Remove the output bin.
5. Press the thumb tabs to remove the lower fold-chute.

Steps 3 to 5: Open the top cover and remove the attachments

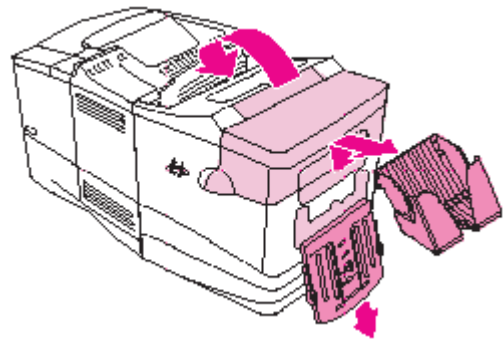

6. Locate the jam-clearing knob at the end of the upper roller and rotate the knob in either direction with one hand while pulling the jammed media out with the other hand, if necessary.

Step 6: Rotate the jam-clearing knob

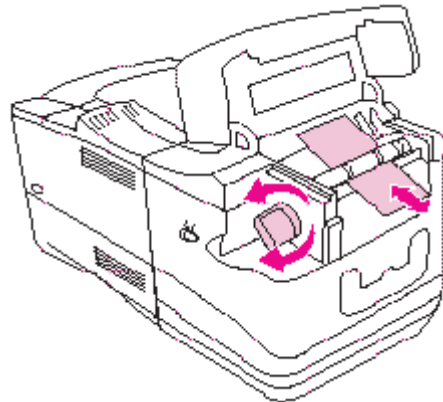

NOTE: Avoid ripping media (paper) from the accessory. Rotate the knob in the direction of least resistance.

7. Close the top cover.
8. Check the fold-chutes to make sure that they are clear of media and that the correct settings are still in place.
9. Replace both fold-chutes and the output bin.
10. Press the power switch of the accessory to the on position.

NOTE: Depending on the nature of the accessory jam, the printer might stop immediately. If it does, a jam condition might have occurred in the printer. The paper path jam in the printer must also be cleared before operation can resume.

Resetting the accessory

After clearing a jam, reset the accessory using one of the three methods below:

- Remove and reinstall the upper fold-chute.
- Remove and reinstall the output bin.
- Set the accessory power switch to standby, and then back to the on position.

Jam recovery for the Print to Mail accessory

After a jam is cleared, when jam recovery is enabled the printer reprints pages that might have jammed. Check the output to see which pages should be reprinted. When printing certain items (such as checks), disable jam recovery to prevent reprinting.

To disable jam recovery

1. Press MENU until CONFIGURATION MENU appears on the printer control panel display.
2. Press ITEM until JAM RECOVERY appears on the display.
3. Press VALUE until JAM RECOVERY = OFF appears on the display.
4. Press SELECT and then press GO.